

Features

- 500mW Power Dissipation
- General Purpose, Medium Current
- Ideally Suited for Automated Assembly Processes
- **Lead, Halogen and Antimony Free, RoHS Compliant "Green" Device (Notes 2 and 3)**
- **Qualified to AEC-Q101 Standards for High Reliability**

Mechanical Data

- Case: SOD-123
- Case Material: Molded Plastic. UL Flammability Classification Rating 94V-0
- Moisture Sensitivity: Level 1 per J-STD-020D
- Terminals: Solderable per MIL-STD-202, Method 208
- Lead Free Plating (Matte Tin Finish annealed over Alloy 42 leadframe)
- Polarity: Cathode Band
- Ordering Information: See Page 3
- Marking Information: See Page 3
- Weight: 0.01 grams (approximate)



Top View

Maximum Ratings @ $T_A = 25^\circ\text{C}$ unless otherwise specified

Characteristic	Symbol	Value	Unit
Forward Voltage @ $I_F = 10\text{mA}$	V_F	0.9	V

Thermal Characteristics

Characteristic	Symbol	Value	Unit
Power Dissipation (Note 1)	P_D	500	mW
Thermal Resistance, Junction to Ambient Air (Note 1)	$R_{\theta JA}$	350	$^\circ\text{C/W}$
Operating and Storage Temperature Range	T_J, T_{STG}	-65 to +150	$^\circ\text{C}$

- Notes:
1. Device mounted on ceramic PCB; 7.6 mm x 9.4 mm x 0.87 mm with pad areas 25 mm².
 2. No purposefully added lead. Halogen and Antimony Free.
 3. Product manufactured with Data Code V9 (week 33, 2008) and newer are built with Green Molding Compound. Product manufactured prior to Date Code V9 are built with Non-Green Molding Compound and may contain Halogens or Sb₂O₃ Fire Retardants.

Electrical Characteristics @T_A = 25°C unless otherwise specified

Type Number	Type Code	Zener Voltage Range (Note 5)			Test Current	Maximum Zener Impedance (Note 4)		Maximum Reverse Leakage Current (Note 5)	
		V _Z @ I _{ZT}				I _{ZT}	Z _{ZT} @ I _{ZT}	Z _{ZK} @ I _{ZK} = 0.25mA	I _R
		Nom (V)	Min (V)	Max (V)	mA	Ω		μA	V
MMSZ5221B	C1	2.4	2.28	2.52	20	30	1200	100	1.0
MMSZ5223B	C3	2.7	2.57	2.84	20	30	1300	75	1.0
MMSZ5225B	C5	3.0	2.85	3.15	20	30	1600	50	1.0
MMSZ5226B	G1	3.3	3.14	3.47	20	28	1600	25	1.0
MMSZ5227B	G2	3.6	3.42	3.78	20	24	1700	15	1.0
MMSZ5228B	G3	3.9	3.71	4.10	20	23	1900	10	1.0
MMSZ5229B	G4	4.3	4.09	4.52	20	22	2000	5.0	1.0
MMSZ5230B	G5	4.7	4.47	4.94	20	19	1900	5.0	2.0
MMSZ5231B	E1	5.1	4.85	5.36	20	17	1600	5.0	2.0
MMSZ5232B	E2	5.6	5.32	5.88	20	11	1600	5.0	3.0
MMSZ5233B	E3	6.0	5.70	6.30	20	7	1600	5.0	3.5
MMSZ5234B	E4	6.2	5.89	6.51	20	7	1000	5.0	4.0
MMSZ5235B	E5	6.8	6.46	7.14	20	5	750	3.0	5.0
MMSZ5236B	F1	7.5	7.13	7.88	20	6	500	3.0	6.0
MMSZ5237B	F2	8.2	7.79	8.61	20	8	500	3.0	6.5
MMSZ5238B	F3	8.7	8.27	9.14	20	8	600	3.0	6.5
MMSZ5239B	F4	9.1	8.65	9.56	20	10	600	3.0	7.0
MMSZ5240B	F5	10	9.50	10.50	20	17	600	3.0	8.0
MMSZ5241B	H1	11	10.45	11.55	20	22	600	2.0	8.4
MMSZ5242B	H2	12	11.40	12.60	20	30	600	1.0	9.1
MMSZ5243B	H3	13	12.35	13.65	9.5	13	600	0.5	9.9
MMSZ5245B	H5	15	14.25	15.75	8.5	16	600	0.1	11
MMSZ5246B	J1	16	15.20	16.80	7.8	17	600	0.1	12
MMSZ5248B	J3	18	17.10	18.90	7.0	21	600	0.1	14
MMSZ5250B	J5	20	19.00	21.00	6.2	25	600	0.1	15
MMSZ5251B	K1	22	20.90	23.10	5.6	29	600	0.1	17
MMSZ5252B	K2	24	22.80	25.20	5.2	33	600	0.1	18
MMSZ5254B	K4	27	25.65	28.35	5.0	41	600	0.1	21
MMSZ5255B	K5	28	26.60	29.40	4.5	44	600	0.1	21
MMSZ5256B	M1	30	28.50	31.50	4.2	49	600	0.1	23
MMSZ5257B	M2	33	31.35	34.65	3.8	58	700	0.1	25
MMSZ5258B	M3	36	34.20	37.80	3.4	70	700	0.1	27
MMSZ5259B	M4	39	37.05	40.95	3.2	80	800	0.1	30

- Notes: 4. f = 1KHz.
5. Short duration pulse test used to minimize self-heating effect.

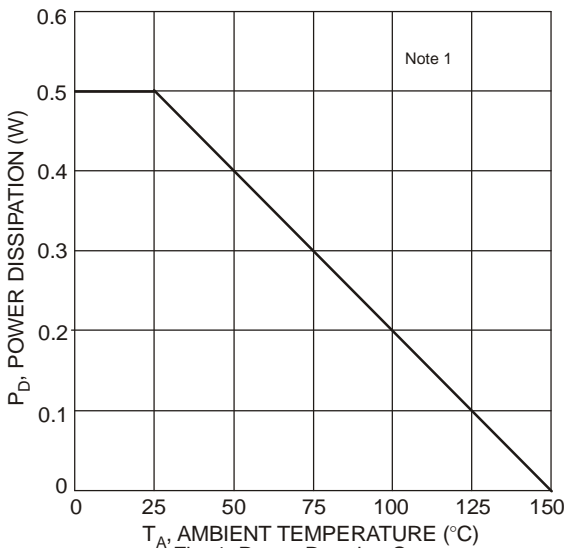

Fig. 1 Power Derating Curve

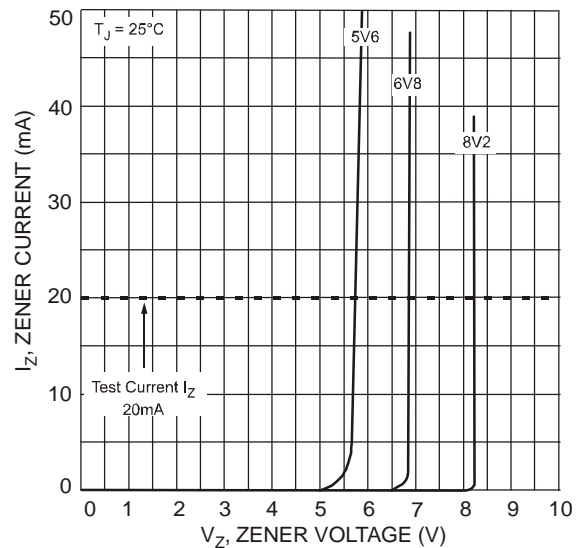

Fig. 2 Typical Zener Breakdown Characteristics

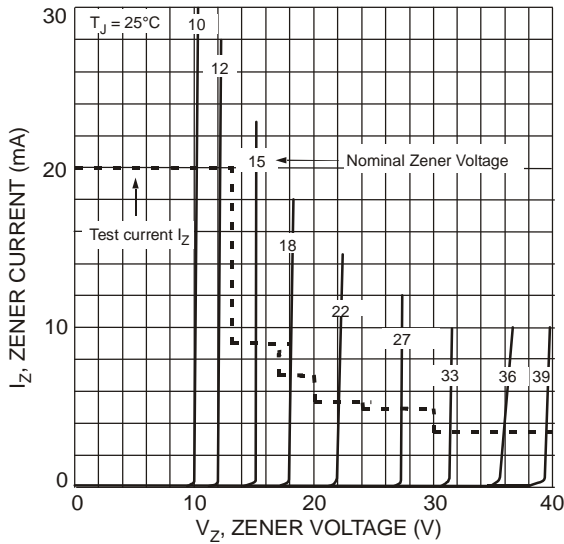

Fig. 3 Typical Zener Breakdown Characteristics

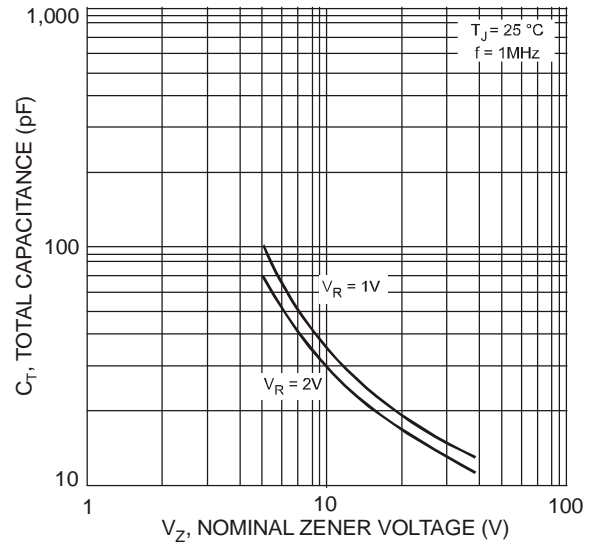

Fig. 4 Typical Total Capacitance vs. Nominal Zener Voltage

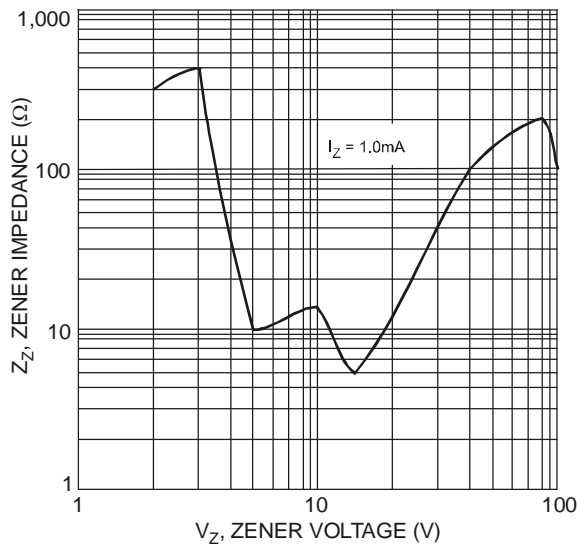

Fig. 5 Typical Zener Impedance Characteristics

Ordering Information (Note 6)

Part Number	Case	Packaging
(Type Number)-7-F*	SOD-123	3000/Tape & Reel

*Add "-7-F" to the appropriate type number in Electrical Characteristics Table. Example: 6.2V Zener = MMSZ5234B-7-F.

Notes: 6. For packaging details, go to our website at <http://www.diodes.com/datasheets/ap02007.pdf>.

Marking Information



xx = Product Type Marking Code
 (See Electrical Characteristics Table)
 YM = Date Code Marking
 Y = Year (ex: N = 2002)
 M = Month (ex: 9 = September)

Date Code Key

Year	1998	1999	2000	2001	2002	2003	2004	2005	2006	2007	2008	2009	2010	2011	2012	2013	2014	2015
Code	J	K	L	M	N	P	R	S	T	U	V	W	X	Y	Z	A	B	C
Month	Jan	Feb	Mar	Apr	May	Jun	Jul	Aug	Sep	Oct	Nov	Dec						
Code	1	2	3	4	5	6	7	8	9	O	N	D						

Package Outline Dimensions

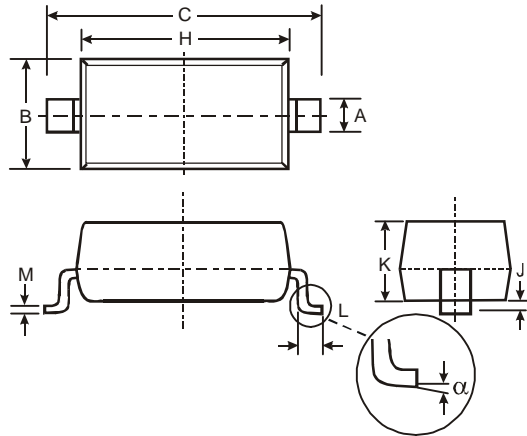

SOD-123		
Dim	Min	Max
A	0.55 Typ	
B	1.40	1.70
C	3.55	3.85
H	2.55	2.85
J	0.00	0.10
K	1.00	1.35
L	0.25	0.40
M	0.10	0.15
α	0	8°
All Dimensions in mm		

Suggested Pad Layout

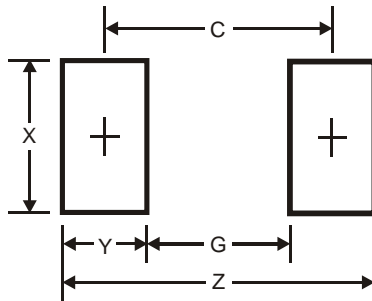

Dimensions	Value (in mm)
Z	4.9
G	2.5
X	0.7
Y	1.2
C	3.7

IMPORTANT NOTICE

Diodes Incorporated and its subsidiaries reserve the right to make modifications, enhancements, improvements, corrections or other changes without further notice to any product herein. Diodes Incorporated does not assume any liability arising out of the application or use of any product described herein; neither does it convey any license under its patent rights, nor the rights of others. The user of products in such applications shall assume all risks of such use and will agree to hold Diodes Incorporated and all the companies whose products are represented on our website, harmless against all damages.

LIFE SUPPORT

Diodes Incorporated products are not authorized for use as critical components in life support devices or systems without the expressed written approval of the President of Diodes Incorporated.